

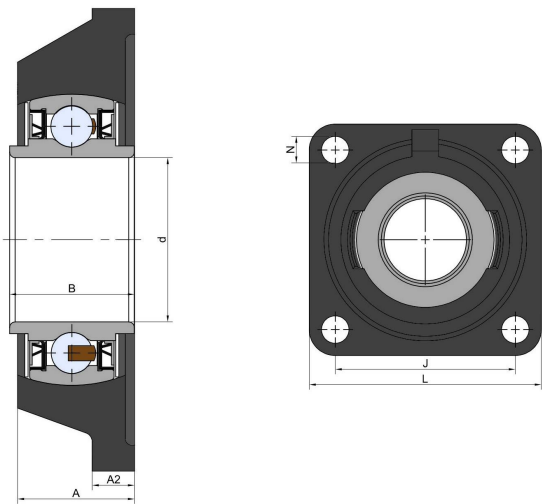

LSQFH 210 2PB.H

Agricultural machinery bearings

技术信息



主要尺寸和性能参数

d1	50mm	Bore diameter
L	143mm	Total length
J	111mm	Distance between the holes
A	38.5mm	Overall width
A1	13mm	Housing flange thickness
≈m	2.47Kg	weight
Cr	56Kn	Radial static load rating
Cor	45Kn	Radial dynamic load rating
Pu	1.89Kn	Fatigue load limit
B	38.4mm	Width inner ring

*数据表仅为所选产品的尺寸和基本额定载荷概览。请始终遵守本产品的所有更多信息和指南。您可通过我们网站上的联系表了解更多信息。

联系方式：邮箱：mr.suo@zrbearing.net

电话：0319-8509111

地址：河北省临西县城北环路北侧-中达轴承