

UH 211/50 2S.T

Agricultural machinery bearings

技术信息

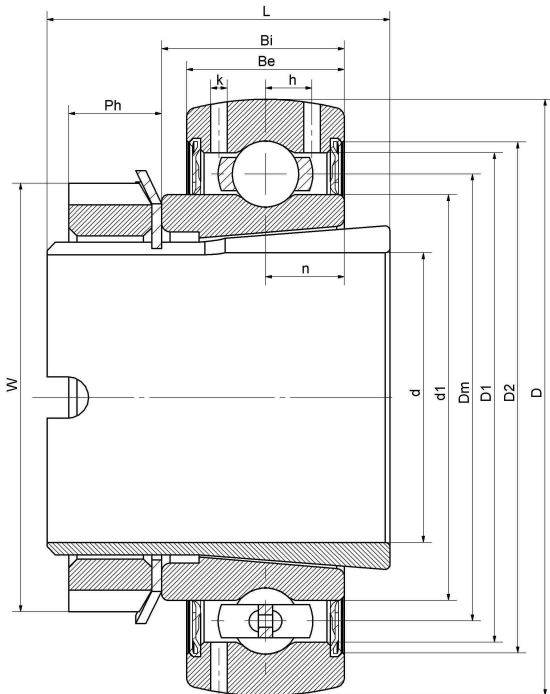

主要尺寸和性能参数

d1	50mm	Bore diameter
D	100mm	Outside diameter
W	75mm	KM nut outside diameter
D2	81mm	MB Washer outside diameter
B	45mm	Width inner ring
B1	25mm	Width adapter sleeve
C	25mm	Width outer ring
L	11mm	KM nut width
E1	7mm	Distance from raceway center to the stopping pin
M	50x2	Thread adapter sleeve
P	3mm	Stop pin diameter
P1	2mm	Stop pin height
≈m	1Kg	weight
Cor	43.6Kn	Radial dynamic load rating
Cr	29Kn	Radial static load rating
Pu	1.25Kn	Fatigue load limit
E	7mm	Distance from raceway centre to the hole for lubrication

*数据表仅为所选产品的尺寸和基本额定载荷概览。请始终遵守本产品的所有更多信息和指南。您可通过我们网站上的联系表了解更多信息。