

Z&R®



## UC 310/V3/C12/G2--F

LE 310 2F

UC 310 D1

### 技术信息

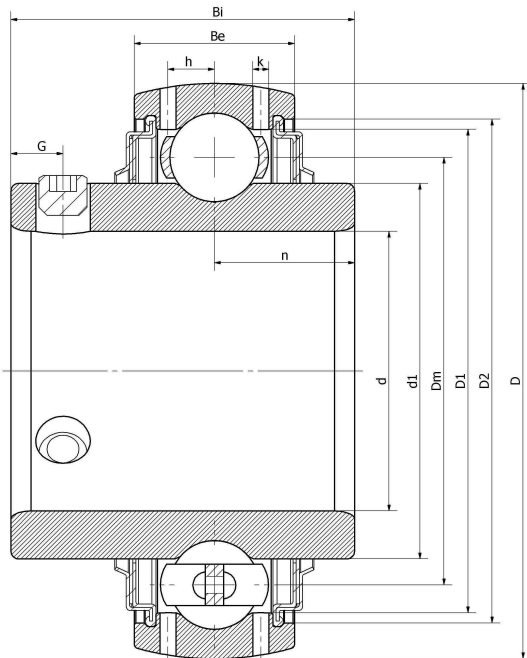

#### 主要尺寸和性能参数

d	50mm	Inside diameter
D	110mm	Outside diameter
d1	登录可见尺寸, 去登录	Outer diameter innering
d1	80.5mm	Center diameter
D1	登录可见尺寸, 去登录	Outer ring inner diameter
D2	登录可见尺寸, 去登录	Seal groove diameter
Be	32mm	Outer ring height
h	10.2mm	Oil hole distance
n	22mm	channel distance
Bi	61mm	Inner ring height
k	1.8mm	Oil hole diameter
G	12mm	Set screw hole distance
(UNF)	M12*1.25	Set screw specifications
Cr	53000N	Radial static load rating
Cor	31900N	Radial dynamic load rating
≈m	1.7KG	weight

\*数据表仅为所选产品的尺寸和基本额定载荷概览。请始终遵守本产品的所有更多信息和指南。您可通过我们网站上的联系表了解更多信息。